

Analysis of Rail Vehicle Suspension Spring with Special Emphasis on Curving, Tracking and Tractive Efforts

This content has been downloaded from IOPscience. Please scroll down to see the full text.

2016 IOP Conf. Ser.: Mater. Sci. Eng. 149 012131

(<http://iopscience.iop.org/1757-899X/149/1/012131>)

View [the table of contents for this issue](#), or go to the [journal homepage](#) for more

Download details:

IP Address: 117.239.44.147

This content was downloaded on 07/02/2017 at 10:09

Please note that [terms and conditions apply](#).

You may also be interested in:

[Experimental Prospects of Neutrinoless Double Beta Decay](#)

Ettore Fiorini

[Atomic population kinetics in fluctuating plasmas](#)

F Catoire, J Rosato, Y Marandet et al.

[Quantum-state input–output relations for absorbing cavities](#)

M Khanbekyan, D-G Welsch, A A Semenov et al.

[Additions to the spectra and energy levels of the zinc-like ions Y X-Cd XIX](#)

Ulf Litzén and Anna Hansson

[Neutrino electromagnetic properties and new bounds on neutrino magnetic moments](#)

K A Kouzakov, A I Studenikin and M B Voloshin

[Regular and singular integrals for relativistic and QED matrixelements](#)

Vladimir I Korobov

[Long-baseline sensitivity studies and comparison \(discussion session\)](#)

Walter Winter

[Material performance of tungsten coatings under transient heat loads](#)

C Thomser, J Linke, G Matthews et al.

[Isospin Effect of the Pairing Correlation in Al Isotopes](#)

Zhang Hu-Yong, Shen Wen-Qing, Ren Zhong-Zhou et al.

Analysis of Rail Vehicle Suspension Spring with Special Emphasis on Curving, Tracking and Tractive Efforts

M. A. Kumbhalkar*, **D. V. Bhope**** and **A. V. Vanalkar***

*Department of Mechanical Engineering,
KDK College of Engineering, Nagpur, Maharashtra, India

E-mail: manoj.kumbhalkar@rediffmail.com

**Department of Mechanical Engineering,
Rajiv Gandhi College of Engineering, Research and Technology, Chandrapur, Maharashtra, India

Abstract. The dynamics of the rail vehicle represents a balance between the forces acting between wheel and rail, the inertia forces and the forces exerted by suspension and articulation. Axial loading on helical spring causes vertical deflection at straight track but failures calls to investigate for lateral and longitudinal loading at horizontal and vertical curves respectively. Goods carrying vehicle has the frequent failures of middle axle inner suspension spring calls for investigation. The springs are analyzed for effect of stress concentration due to centripetal force and due to tractive and breaking effort. This paper also discusses shear failure analysis of spring at curvature and at uphill at various speeds for different loading condition analytically and by finite element analysis. Two mass rail vehicle suspension systems have been analyzed for vibration responses analytically using mathematical tool Matlab Simulink and the same will be evaluated using FFT vibration analyzer to find peak resonance in vertical, lateral and longitudinal direction. The results prove that the suspension acquires high repeated load in vertical and lateral direction due to tracking and curving causes maximum stress concentration on middle axle suspension spring as height of this spring is larger than end axle spring in primary suspension system and responsible for failure of middle axle suspension spring due to high stress acquisition.

Keywords. Helical spring, curving, tractive effort, FEA, vibration.

1. Introduction

A most complex dynamical system in engineering involves the rail vehicle running along a track. The history of railway engineering has many practical examples of dynamical problems which have degraded performance and safety. Inadequate guidance on curves results in high lateral forces between wheel and rail, rapid wear of wheels and rails and the possibility of derailment. Static and dynamic instabilities, and response to track irregularities and other features of track geometry, can result in poor ride quality and high stresses and can contribute to derailment. Running on curvature involves the control of forces acting between the vehicles and track as the propulsive and braking forces are varied in response to the train traversing hills and valleys. High frequency interaction between wheel and rail can lead to excess deformation of suspension, damage to the contacting surfaces and corrugation of the rails, and excessive noise and vibration [1, 15].

The major part of rail vehicle is three axles, three motor Co-Co bogie assemblies. An entire weight of 123 tonne of locomotive is supported by two bogie assemblies and provides a means for transmission of the tractive effort to the rails. A rail vehicle is designed to withstand the stresses and vibrations resulting from normal rolling stock applications. An important function of the bogie is to



absorb and isolate shock caused by variations in the trackbed. The suspension systems minimize the transmission of these shocks to the locomotive under frame [2].

A circular helix is referred for point (x,y,z) revolve around y -axis at a constant radius R from it and simultaneously moves parallel to y -axis in such a way that its y -component is proportional to the angle of revolution path. Due to its revolution spring experience a twisting moment which stretches body on outside diameter. Because of direct load and twisting effect, a shear stress is acting on spring [5, 6]. A helicoidal spring with pitch h , coil diameter d and mean radius R is shown in figure 1.

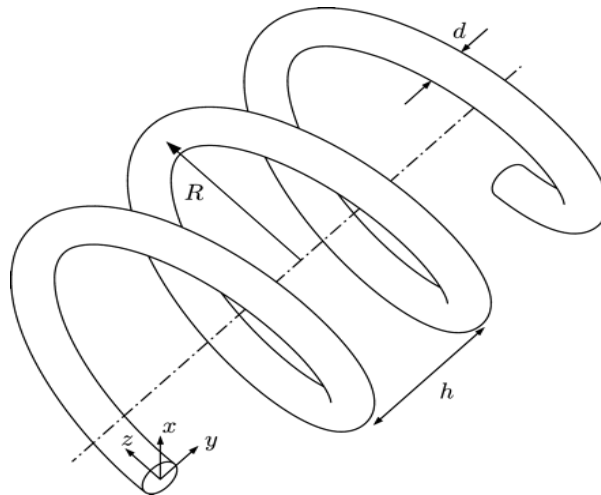

Figure 1. Helicoidal Spring

The rail vehicle has two types of suspension spring viz. primary and secondary suspension spring. The two sets of primary suspension springs are mounted near each wheel. The vehicle having total six axles which divided in two frames i.e. three axles on frontal side and three axles on rear side. Among three suspension spring middle axle has composite set of assembly of inner and outer spring and linkage to move laterally at horizontal curves. The remaining two axles i.e. end axles only has two sets of primary spring whose free height is less than middle axle spring and having damper provided between axle and frame to restrict lateral deflection.

This case study reveals the high stresses and deflection occurs on springs in lateral and longitudinal direction responsible for the failure due to shear stress concentration. The analysis has been carried out for various horizontal and vertical curved radiuses of the Indian tracks. The observation finds the exact stress concentration over spring at the 2nd to 3rd coil from the top end. The lateral and longitudinal seam of load causes the extra deflection and affects spring causes maximum shear stress in inside diameter. During experimentation the amplitude of vibration also expresses very high fluctuation in lateral side while running on curved track and during tracking.

2. Lateral Forces On Curve Track

The vehicle changes continuously its direction when it is passing over the curve. The vehicle tends to continue moving in the straight line but due to inertia the force change in direction of the movement by track gives rise to lateral acceleration acting outwards which is felt by the vehicle. Due to this centripetal force, the vehicle will experience lateral forces in the railway track when travels in curved path [3,4]. The various parameters which affect the design and maintenance of horizontal curves are radius (R), cant/superelevation (C), equilibrium speed (V_{eq}), cant deficiency (C_d), cant excess (C_{ex}) and cant angle. The dimensions to analyze the lateral effect on the suspension spring over broad gauge (BG) track for the given parameters are shown in table 1.

To negotiate curves on the railway track, only the middle axles are given the free play of about 16 mm in a lateral direction, where concentric helicoidal suspension springs are mounted without

dashpot, perpendicular to the direction of motion of vehicle. It has been observed that the axle do not turn about the vehicle but there is a sliding of the middle axle which helps in negotiating the curve. The forces between wheel and rail generating forces act toward the center of the horizontal curvature of the trajectory of the rails, whose resultant acceleration is known as centripetal acceleration. While moving on the curved track the vehicle is subjected to additional lateral force because of centripetal force which causes the lateral force on the spring with its bending moment maximum at the top end. The centripetal force due to centripetal acceleration on curved track is shown in figure 2 and its lateral effect on suspension spring is shown in figure 3.

Table 1. Design parameter for Curves

Sr. No.	Parameters	Notation	BG
1	Radius of curve (m)	R	175, 252, 292
2	Cant/superelevation (mm)	C _a	140
3	Cant Deficiency (mm)	C _d	75
4	Cant excess(mm)	C _{ex}	75
5	Cant Angle (degree)	A	6
6	Speed of Vehicle (km/hr)	V	60-100
7	Distance between track (mm)	X	1676
8	Height of CG (mm)	H	1450.66
9	Mass of bogie (kg)	M	99096
10	Diameter of wheel (mm)	D	1016

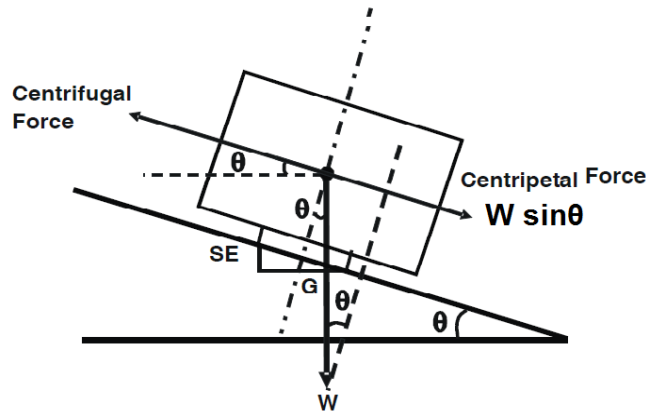

Figure 2. Rail vehicle on curved track [3]

To decide maximum force occurs at outer or inner rail at curved track, the forces has been resolved perpendicular to track. The expressions to find reaction at inner and outer rail are as follows,

$$R_{wA} + R_{wB} = F_c \sin \theta + W \cos \theta = \frac{mV^2}{R} \sin \theta + mg \cos \theta$$

$$R_A \times x = (F_c \sin \theta + W \cos \theta) \frac{x}{2} + (W \sin \theta \times h) - (F_c \cos \theta \times h)$$

$$R_A = \left(\frac{mV^2}{R} \sin \theta + mg \cos \theta \right) \frac{1}{2} + \left(mg \sin \theta - \frac{mV^2}{R} \cos \theta \right) \frac{h}{x} \tag{1}$$

$$R_B = (R_A + R_B) - R_A$$

Gyroscopic couple, $C = I \omega_w \cos\theta \omega_p$

Reaction at gyroscopic couple, $R_{GA} = R_{GB} = C_G/x$

Reaction at outer rail, $R_B = \uparrow R_{WB} + \uparrow R_{GB}$

Reaction at inner rail, $R_A = \uparrow R_{WA} - \downarrow R_{GA}$

Due to gyroscopic effect, the reactions are occurring on inner and outer wheel which affects on the suspension of railway vehicle. The force is observed to be more on outer wheel and occurs extra deformation of springs at outer wheel. The equation of shear stress for helical spring is defined by spring index and shear stress factor which is a measure of coil curvature and direct stress. Therefore the shear stress (τ) and Wahl's stress factor (K) is defined by following equation [5, 6].

$$\tau = K \frac{8FD}{\pi d^3} \quad \text{and} \quad K_w = \frac{4C-1}{4C-4} + \frac{0.615}{C} \tag{2}$$

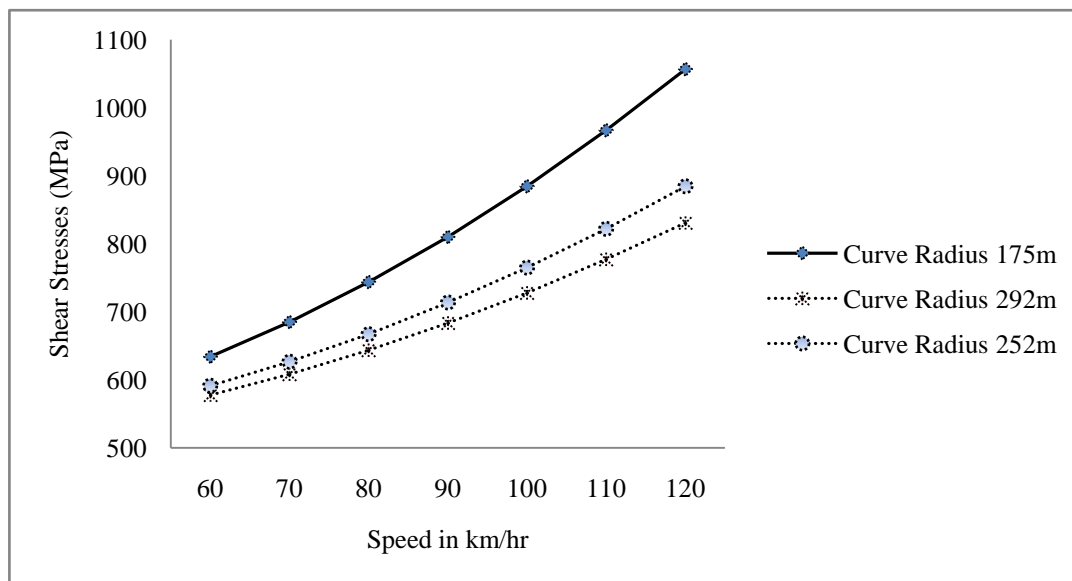

Figure 3. Shear Stresses on Inner spring at different curved radius at various speeds

3. Tractive and Breaking Effort

The force which a rail vehicle can exert when pulling a train is called its tractive effort, and depends on various factors. For electric rail vehicle, which obtain their power by drawing current from an external supply, the most important are the adhesion between the driving wheels and the track depends on the weight per wheel, and determines the force that can be applied before the wheels begin to slip and up to a certain speed, the tractive effort is almost constant [14]. The current in the traction motor falls due to increase in speed and hence so does the tractive effort. TE/BE meter shows the readings of tractive and braking effort at various speed has been recorded from the driver cab [2] is shown in figure 4.

From the reading of tractive and braking effort, it is observed that the tractive effort is maximum during starting of vehicle and constant while running. Therefore additional load of 460KN is forced on the suspension spring during starting of vehicle in longitudinal direction and about 300KN load is acted during running condition which may cause the extra deformation of springs and causes more stresses. The stresses on each primary suspension spring at various speed due to tractive and braking effort is shown in figure 5 and figure 6 respectively. The stresses on each springs are obtained by taking the addition deflection of end axle spring due to tractive effort which is obtained by considering the load acted on total 16 spring by using following relation,

$$W = [(W_e \times 8) + (W_o \times 4) + (W_i \times 4)] \delta$$

$$W = [(K_e \times 8) + (K_o \times 4) + (K_i \times 4)] \delta \tag{3}$$

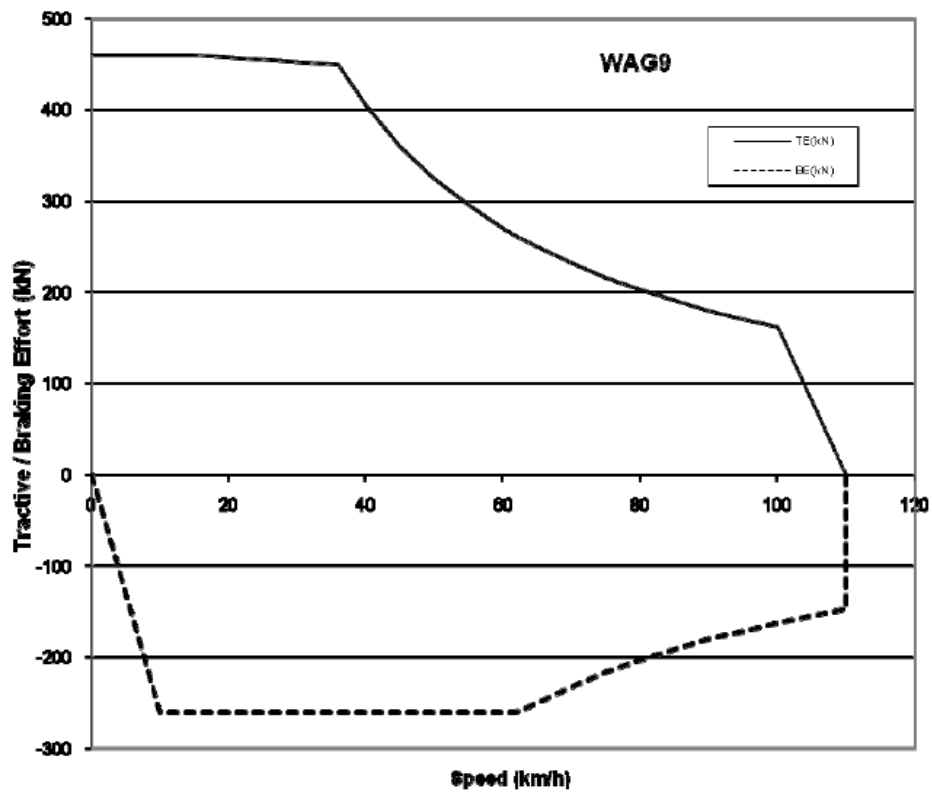

Figure 4. Tractive and Braking effort at various speed [2]

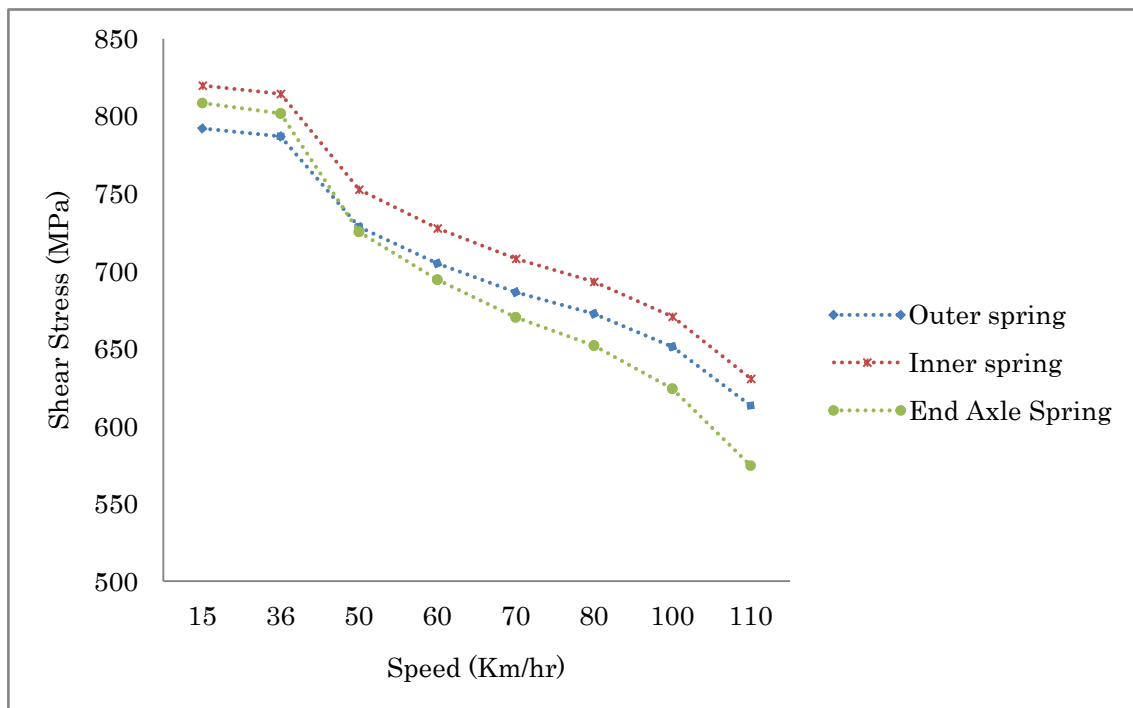

Figure 5. Shear stresses on primary suspension springs at various speeds due to tractive effort

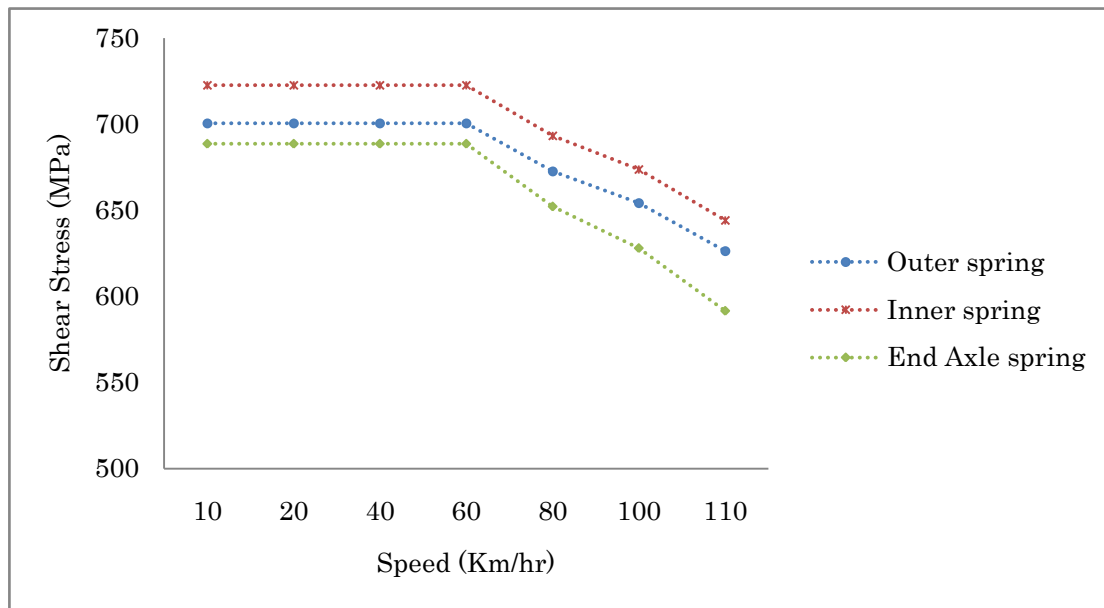

Figure 6. Shear stresses on primary suspension springs at various speeds due to braking effort

4. Rail Vehicle at Uphill

A rail vehicle exerts a drag to propelling it during running condition. Drag opposes motion of rail body occurs due to variety of sources, air resistance, resistance from the rail as the wheels roll along it and most important being friction in axle bearings. The drag has been estimated by operator by measuring forces during experimentation to keep a rail vehicle running at constant speed. Polynomials can be used to approximate the variation of drag with speed [9,14]. The drag might be given approximately by:

$$Q(v) = 2000 + 20v + 3.5v^2 \tag{4}$$

where Q stand for the drag in newtons, and v for the speed in metres per second. The brake force applied depending the factors of friction between rail and wheels being braked, and the normal reaction of the rail on the wheels being braked[9,14]. It is specified as a fraction β of the total weight of the train. A typical value for β is 0.09.

$$B = mg\beta \tag{5}$$

The dynamics of a train moving with speed v along a track inclined at an angle α to the horizontal are determined by the forces shown in Figure 8.

By Newton’s second law of motion, the acceleration ‘a’ is given by:

$$\begin{aligned} ma &= P(v) - Q(v) - B - mg \sin \alpha \\ P(v) &= Q(v) + B + mg \sin \alpha + ma \end{aligned} \tag{6}$$

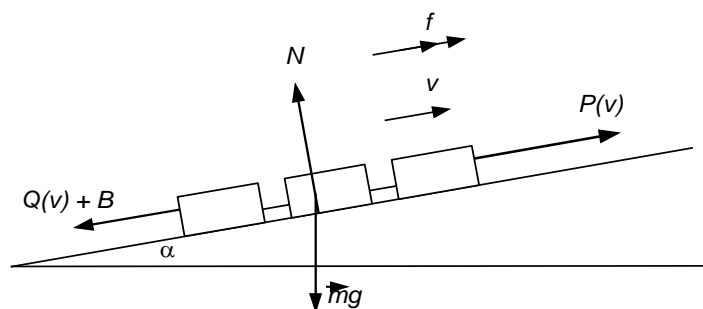

Figure 7. Rail Vehicle at uphill

A vehicle required more effort to haul the good at uphill and responsible for the longitudinal load on the spring. The railway tracks are not enough elevated than 2 to 3 degree of cant angle but analysis has been carried out upto 10 degree of cant angle and for distance travel of 500m and 1000m shown in figure 8 and figure 9 respectively. Using the above equation, the tractive effort and stresses are computed at various cant angles and at distance to be traveled shown in table 2.

Table 2. Cant angle at different traveling distance

Sr. No.	Cant Angle ' α ' (degree)	Distance Travel 'S ₁ '(meter)	Distance Travel 'S ₂ '(meter)
1	2	500	1000
2	4	500	1000
3	6	500	1000
4	8	500	1000
5	10	500	1000

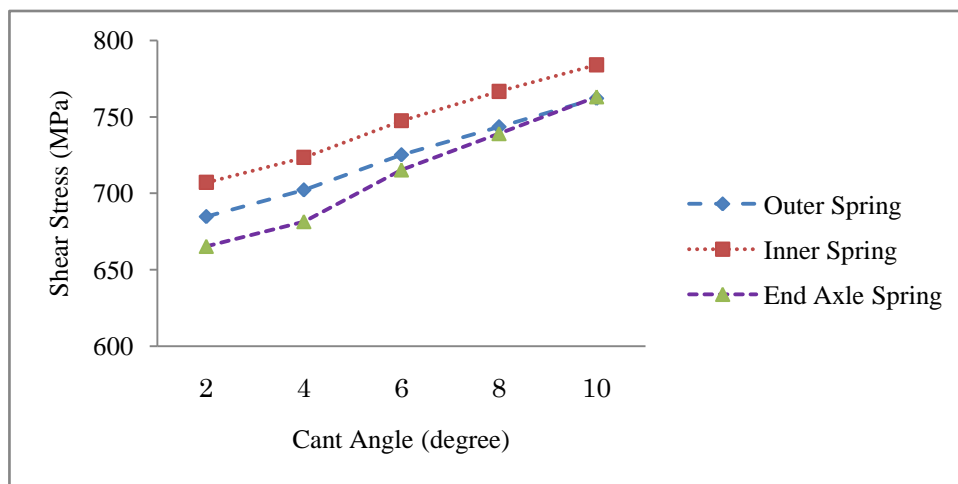

Figure 8. Shear stresses on primary springs at uphill at various cant angles and distance travel of 500m

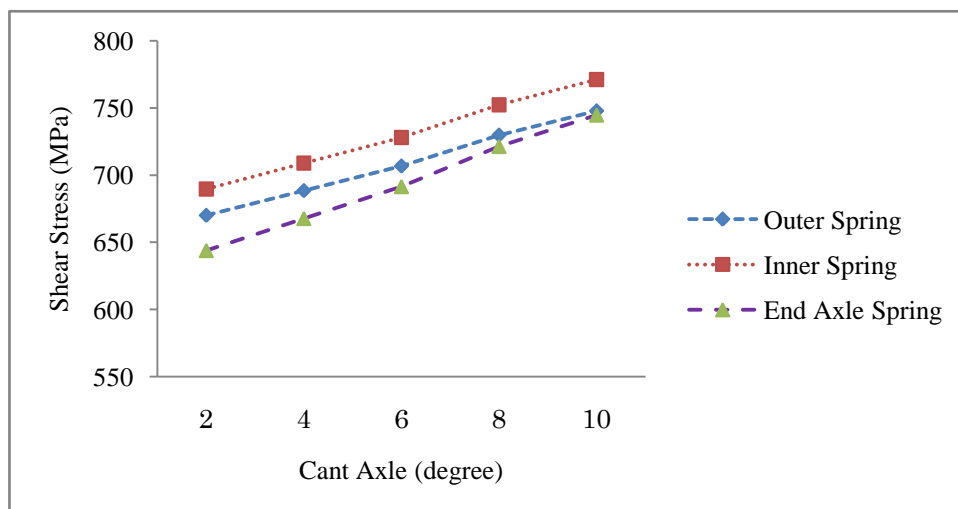

Figure 9. Shear stresses on primary springs at uphill at various cant angles and distance travel of 1000m

5. Finite Element Analysis of Suspension Spring

A rail vehicle has frequent failure of middle axle inner suspension spring in many instances is call for investigation. Finite element analysis is a technique to find elemental solution over the body helps to find maximum stress concentration as the spring starts shearing from its inner diameter. An analysis has been carried out on 1/4th coil and one turn of inner spring to find stress concentration. The analytical cases considered above are used for shear stress analysis in standard tool of finite element analysis. Both models are course mesh with solid 186 hexahedral element which is a higher order 3-D 20 node solid element that exhibits quadratic displacement behavior. For analysis, forces calculated in above cases are applied at one end in the direction of its center and other end is fixed in all degree of freedom. Finite element analysis of 1/4th coil and one turn of middle axle inner suspension spring is shown in figure 10 and its comparative results with analytical shear stress is shown in table 3. Figure 10 reveals the stress occur maximum at inner diameter of helical spring from where the shearing may start. It has been observe that the stress is minimum at straight track which is increases slightly over curved track and reaches to ultimate shear stress of 860 N/mm² at tractive effort. The dynamic analysis is referred as the stresses are varying for the varying forces with respect to time. Transient analysis is used to determine the dynamic response of a structure under the action of any general time-dependants load. The transient analysis also has been carried out for the varying forces of 9352N to 12813N for the time period of 10sec. The results for transient analysis for 1/4th and one turn of inner suspension spring are shown in table 4. The analysis reveals that the spring exceeds limiting strength at dynamic condition which is responsible for the failures.

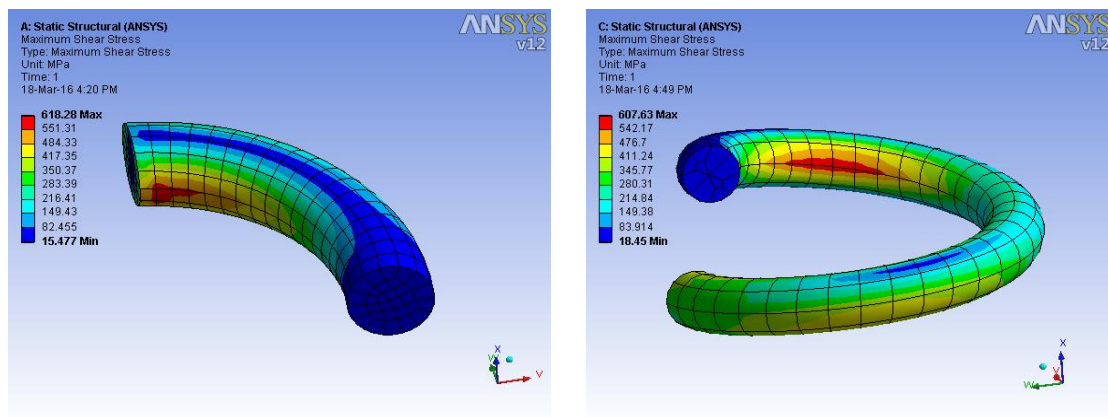

Figure 10. Finite element analysis of 1/4th coil and one revolved coil of middle axle inner suspension spring

Table 3. Results for analytical and finite element analysis of middle axle inner suspension spring

Condition	Force (N)	Finite Element Analysis		Analytical
		Shear stress on 1/4 th curved coil (N/mm ²)	Shear stress on one turn of spring (N/mm ²)	Shear stress on middle axle inner spring (N/mm ²)
At straight track	9352	618.28	607.63	598.36
At curved track	10512	694.97	683	672.96
At breaking effort	11294	746.67	733.81	722.65
At tractive effort	12813	847.1	832.5	819.80
At uphill	12240	809.22	795.27	783.19

Table 4. Transient analysis of 1/4th and one turn of inner suspension spring

Time [s]	Shear stress on 1/4 th curved coil		Shear stress on one turn of spring	
	Minimum (N/mm ²)	Maximum (N/mm ²)	Minimum (N/mm ²)	Maximum (N/mm ²)
1.	15.535	626.35	12.295	643.87
2.	15.535	626.35	12.295	643.87
3.	16.259	655.73	13.424	676.8
4.	16.984	685.15	14.795	710.15
5.	17.708	714.59	16.331	743.81
6.	18.434	744.08	18.048	777.93
7.	19.16	773.6	19.924	812.39
8.	19.887	803.15	21.996	847.34
9.	20.615	832.74	24.237	882.64
10.	21.343	862.36	26.693	918.5

6. Vibration Analysis

Damping control in the primary suspension is applied to the vertical axle-box dampers to suppress the vertical vibrations of the bogies, and hence to reduce the first vertical bending mode of the car body. Furthermore, active damping in the secondary suspension is applied to the spring to suppress the rigid vibration modes bounce and pitch[7,10].

The secondary suspension interconnects and limits the relative vertical displacements between car body and bogie frame, with the purpose of isolating the car body from excitation transmitted from track irregularities via the wheel sets and bogie frames[11]. Figure 11 illustrates the suspension with secondary spring stiffness and high damping longitudinal, horizontal and vertical dashpots attached with them.

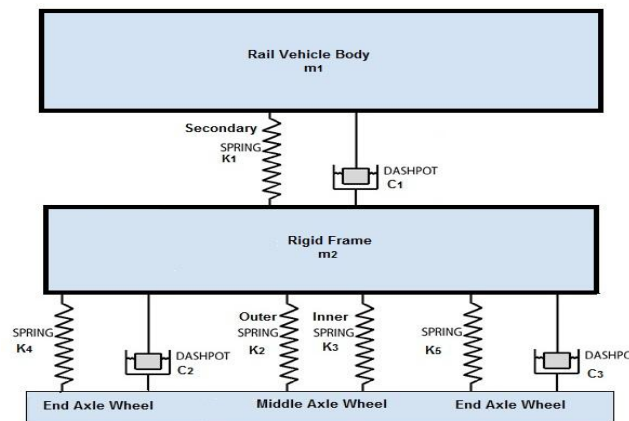

Figure 11. Rail Vehicle suspension system

Differential equation for primary and secondary suspension system i.e. for two DOF of rail road vehicle is obtained by using D’Alembert’s principle,

$$\text{For mass } m_1, \quad m_1 \ddot{x}_1 = -c_1(\dot{x}_1 - \dot{x}_2) - k_1(x_1 - x_2) + f \tag{7}$$

$$\text{For mass } m_2, \quad m_2 \ddot{x}_2 = -c_1(\dot{x}_1 - \dot{x}_2) + k_1(x_1 - x_2) + c_2(\dot{y} - \dot{x}_2) + k_2(y - x_2) - f \tag{8}$$

A mathematical expression for the solution of two degree of freedom system in the form of displacement, velocity and acceleration with respect to time is expressed below. A mathematical tool matlab simulink is used to find an acceleration response for two mass system of rail vehicle suspension. A simulink model for the suspension system having spring and dashpot is shown in figure

12 gives a response of displacement, velocity and acceleration for a dynamic system. An acceleration response has been plotted from the simulink model is shown in figure 13.

$$x = X e^{-\xi \omega_n t} \sin(\omega_d t + \phi) \tag{9}$$

$$\dot{x} = X e^{-\xi \omega_n t} \{ \omega_d \cos(\omega_d t) - \xi \omega_n \sin(\omega_d t) \} \tag{10}$$

$$\ddot{x} = X e^{-\xi \omega_n t} \{ \omega_d (-\omega_d \sin \omega_d t - \xi \omega_n \cos \omega_d t) + \xi \omega_n (\xi \omega_n \sin \omega_d t - \omega_d \cos \omega_d t) \} \tag{11}$$

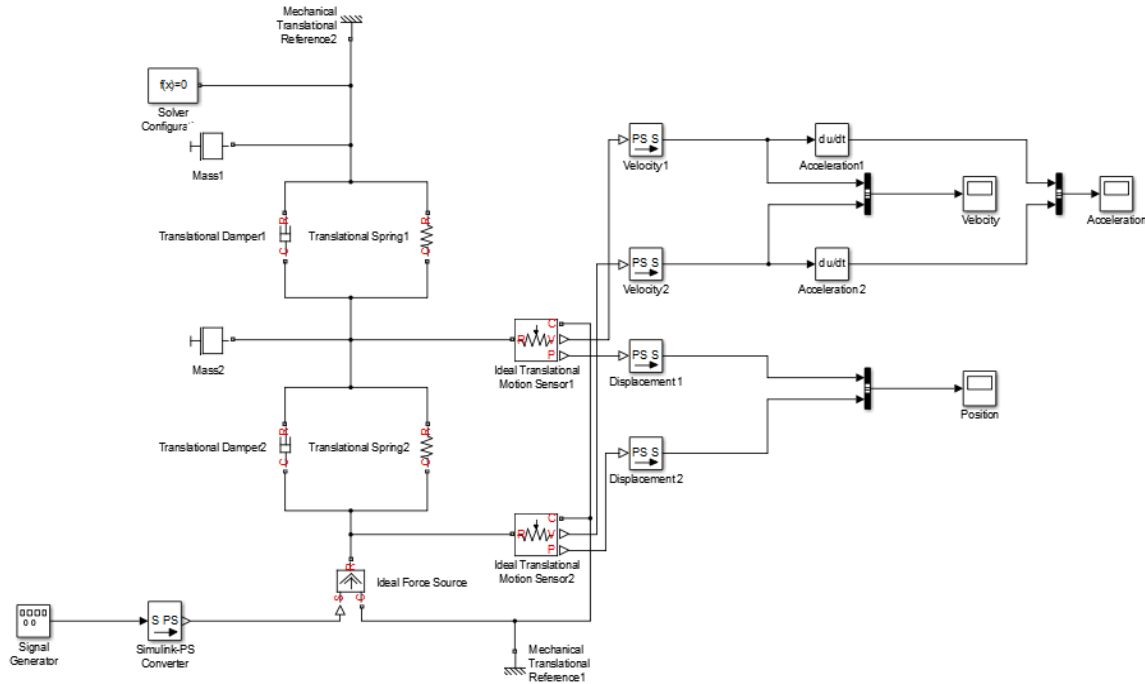

Figure 12. Simulink model of two degree of freedom spring mass damper system

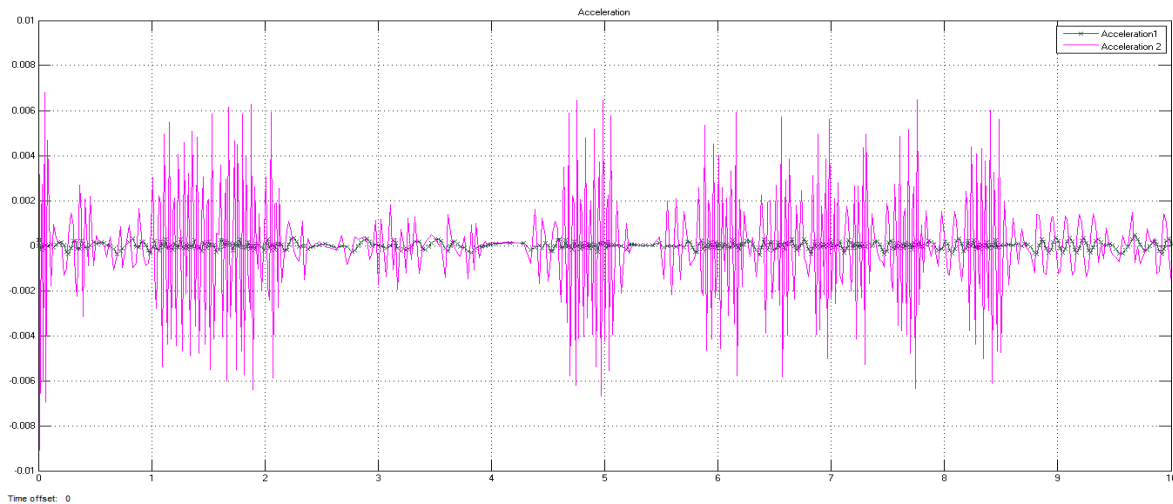

Figure 13. Excitation of acceleration of two mass suspension system of rail vehicle using matlab simulink

Vibration analyzer is used to determine vibration response in all direction in the form of acceleration with respect to time. The analyzer is used to find peak value with respect to calibrated value which determines the dynamic behavior of rail vehicle on running track. The readings have been collected on Indian track condition to analyze fluctuation in vertical, lateral and in longitudinal

direction. The raw acceleration data high-pass filtered to emphasize vibration. The roll-off frequency is 1Hz in high frequency mode and 0.1Hz in low frequency mode. The power spectrum is calculated from 0Hz to the Nyquist frequency. The units are acceleration squared divided by the frequency. To integrate over the power spectrum sum all data and then multiply by the frequency step size. This returns the mean squared amplitude in acceleration units squared [12, 13].

The vibration readings are acquired at an average speed of 80 to 100km/hr. The vibration analyzer has been calibrated with gravity of 9.81 m/s^2 in vertical direction and 0 m/s^2 in lateral and longitudinal direction placed on the platform of frame of suspension system. During acquisition a peak value of acceleration, RMS vibration and PSD resonance in all directions has been recorded at different tracks which are observed to be maximum in vertical and lateral direction during running condition at an average speed of 100km/hr. The responses has been recorded on straight track, curve track and while tracking. The peak responses are observed to be maximum while tracking. The RMS vibration response and power spectrum density at different tracks captured are shown in figure 14.

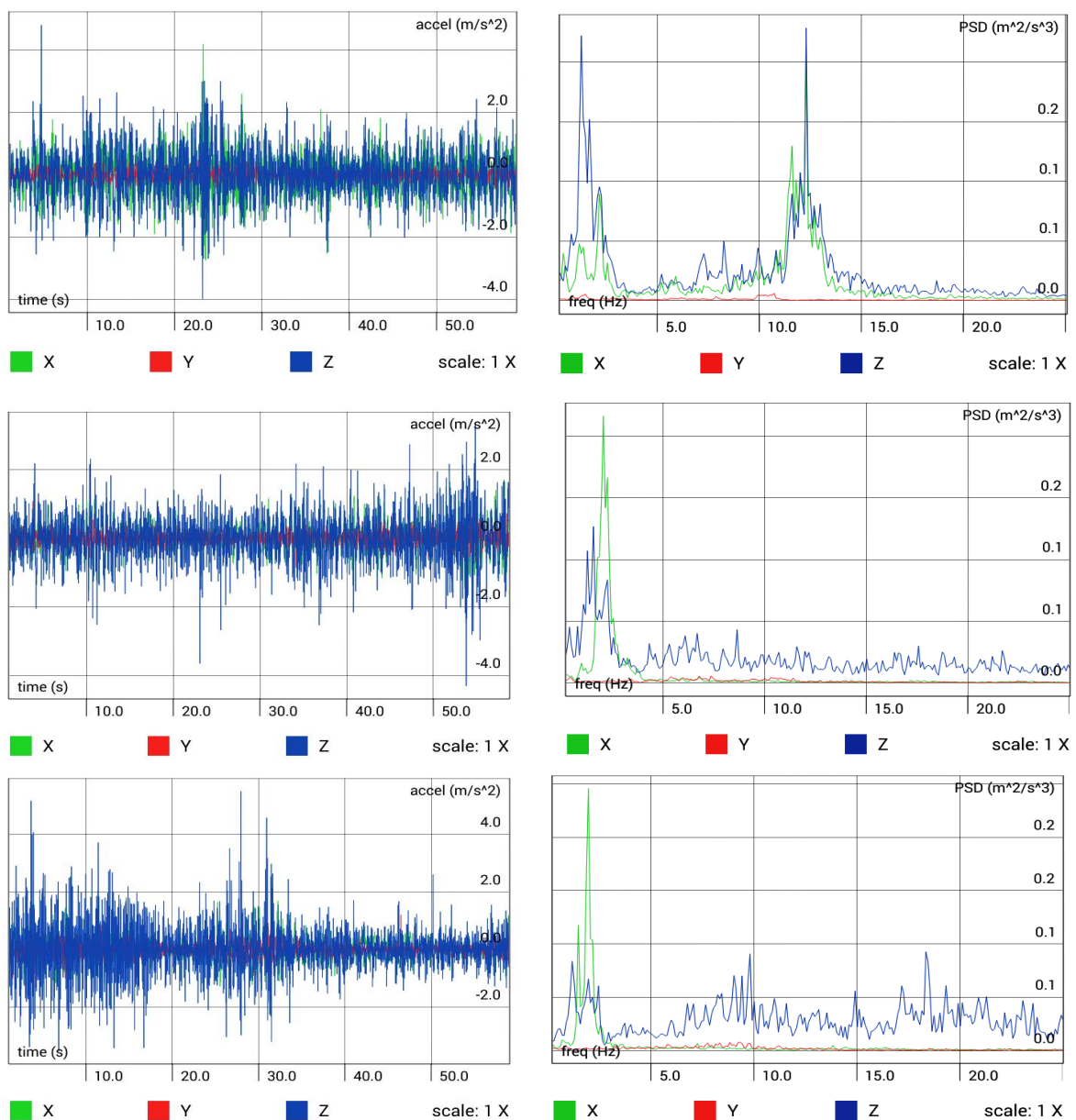

Figure 14. Vibration and power spectrum density (PSD) resonance response of rail vehicle suspension in dynamic condition with average speed of 100km/hr.

7. Conclusion

During dynamic movement of rail vehicle at the curvature and at uphill the effect of stresses has been obtained by using empirical relations. It is observed that the middle axel has the free play of 16 mm in lateral direction at curvatures and therefore experience more stress on inner spring. The shear stresses are increases at curved radius of 292m and 252m than straight track and reach the ultimate limit after speed of 100km/hr. It is again increases for critical curved radius of 175m and after speed of 80km/hr. The dynamic analysis at curvature reveals that the rail suspension causes high shear stress after achieving a speed more than 80km/hr and may fail at certain instance of oscillation due to lateral loading. Apart from the curvature effect, the inner springs may undergo high stress acquisition due to tractive effort which acts longitudinal force with axial load. The shear stress due to tractive and braking effort indicates that the stresses are more during starting of vehicle and decreases or constant while vehicle at constant speed. At uphill, the tractive effort observed to be more at cant angle of 10^0 . Due to tractive and braking effort the suspension spring are compressed and cause maximum shear stresses during starting and stopping of vehicle. Hence the dynamic movements are very critical for suspension spring as it cause deformation of axial, lateral and longitudinal which may starts the shearing at inside diameter of spring and fails due to increase of stresses as observed in finite element analysis of 1/4th and one turn of inner spring. The transient analysis also reveals the stress exceeds the limiting strength of spring material during dynamic condition and may cause failures. The experimental results using vibration analyzer is also reveals that the suspension of rail vehicle experiences more accelerations in vertical direction and even though in lateral and longitudinal direction during dynamic condition. The peak value of acceleration analyzed while tracking and curving in vertical direction is 15.09 m/s^2 , in lateral direction is 1.78 m/s^2 and in longitudinal direction is 1.85 m/s^2 and also PSD resonance of $0.093 \text{ m}^2/\text{s}^3$ at 18Hz in vertical direction, $0.25 \text{ m}^2/\text{s}^3$ at 2Hz in lateral direction and $0.008 \text{ m}^2/\text{s}^3$ at 9.3Hz in longitudinal direction.

References

- [1] H. Wickent 2003 Fundamentals of Rail Vehicle Dynamics *Swets & Zeitlinger Publishers* **1-15** Netherlands.
- [2] Dy.CEE / Design *Indian railways driver's manuals for WAG-9* Ident. No. 3EHW411116 Ver-1 **1-15** India.
- [3] V. B. Sood 2009 Curves for Railway *Indian Institute of Civil Engineering, Pune* **1-20**.
- [4] T. Michaleka, J. Zelenka 2011 Reduction of lateral forces between the railway vehicle and the track in small-radius curves by means of active elements *Applied and Computational Mechanics* Volume 5 **187-196**.
- [5] Koutaro Watanabe, Hideo Yamamoto, Yuichi Ito, Hisao Isobe Simplified Stress Calculation Method for Helical Spring.
- [6] Joseph E. Shigley & Charles R. Mischke 2008 A textbook of Mechanical Engineering Design *Tata McGraw Hill* **502-526**.
- [7] Anneli Orvnas 2010 Method of Reducing Vertical Carbody Vibrations of a Rail Vehicle *Report in Railway Technology Sweden*.
- [8] Khaled E. Zaazaa, Ahmed A. Shabana 2014 Study of the Lateral Stability of Railroad Vehicle Systems Using the Elastic Contact Approach *The Arabian Journal for Science and Engineering* Volume 29 Number 1C **3-12**.
- [9] David Barney, David Haley, George Nikandros 2001 Calculating Train Braking Distance *Conferences in Research and Practice in Information Technology* Vol. 3. P. Lindsay, Ed.
- [10] Prof. S. P. Chavan, Prof. S. H. Sawant, Dr. J. A. Tamboli Experimental Verification of Passive Quarter Car Vehicle Dynamic System Subjected to Harmonic Road Excitation with Nonlinear Parameters *IOSR Journal of Mechanical and Civil Engineering* **39-45**.

- [11] Kazuhiko Nishimura, Yoshiaki Terumichi, Tsutomu Morimura, Kiyoshi Sogabe 2009 Development of Vehicle Dynamics Simulation for Safety Analyses of Rail Vehicles on Excited Tracks *Journal of Computational and Nonlinear Dynamics* Vol. 4 / 011001-1.
- [12] Rajib Ul Alam Uzzal, Waiz Ahmed, Subhash Rakheja 2008 Dynamic Analysis of Railway Vehicle-Track Interactions Due to Wheel Flat with A Pitch-Plane Vehicle Model *Journal of Mechanical Engineering* Vol. ME39 No. 2 *Transaction of the Mechanical Engineering Division* The Institution of Engineers, Bangladesh.
- [13] G. Kumaran, Devdas Menon, K. Krishnan Nair 2003 Dynamic studies of railtrack sleepers in a track structure system *Journal of Sound and Vibration* Volume 268 **485–501**.
- [14] Madalina Dumitriu Influence of the Longitudinal And Lateral Suspension Damping On The Vibration Behavior In The Railway Vehicles *Archive Of Mechanical Engineering* Vol LXII Number 1.
- [15] Dragan Sekulić, Vlastimir Dedović 2011 The Effect Of Stiffness And Damping Of The Suspension System Elements On The Optimization Of The Vibrational Behaviour of A Bus”, *International Journal for Traffic and Transport Engineering* Volume 1(4) **231 – 244**.